

BROY

04.05
IND1-02

SFA

NOTICE D'INSTALLATION	(F)
INSTALLATION INSTRUCTIONS	(UK)
INSTALLATIONSHINWEISE	(D)
STRUZIONI PER L'INSTALLAZIONE	(I)
INSTALLATIE VOORSCHRIFTEN	(NL)
MANUAL DE INSTALACIÓN	(E)
MANUAL DE INSTALAÇÃO	(P)
INSTALLATIONSANVISNING	(S)
INSTALLATIONSVEJLEDNING	(DK)
INSTALLASJONSANVISING	(N)
ASENNUSOHJEET	(FIN)
INSTRUKCJA INSTALACJI	(PL)
FELSZERELÉSI ÉS KEZELÉSI ÚTMUTATÓ	(H)
Инструкция по монтажу и эксплуатации	(R)



1 DESCRIPTION

The macerating system of this unit is installed in a case, specifically designed for horizontal outlet spigots. This macerator manufactured in a factory which is quality certified to ISO 9001(2000) accredited by AFAQ. Correct operation of your unit depends on correct installation and usage. Please pay particular attention to the following:

"  " Possible danger to personnel,

"  " Warning of possible electrical hazard,

"**ATTENTION**" This is a general warning that failure to follow instructions could result in poor functioning of the unit.

This equipment benefits from the latest technological innovations concerning soundproofing. To benefit fully from the advantages provided by this new generation of appliances, it is important to comply with the installation instructions from **7** onwards.

2 LIST OF ACCESSORIES INCLUDED:

See fig. n° **2** (cf. technical data sheet).

3 DIMENSIONS AND OVERALL MEASUREMENTS:

See fig. n° **3** (cf. technical data sheet).

4 TECHNICAL DATA:

This pump/macerator has been designed to pump away the waste from a WC and the sanitary appliances mentioned in fig n° **1** (cf. technical data sheet).

This unit is for domestic use only.

Installed and used correctly, this unit will give consistent and reliable service.

You can find the technical data in fig n° **8** (cf. technical data sheet).

5 PERFORMANCE CURVE:

See fig. n° **5** (cf. technical data sheet).

6 HEIGHT AND LENGTH OF THE DISCHARGE PIPE:

The possible combinations of height and length of the discharge pipe are shown in fig. **6** (cf. technical data sheet).

7 INSTALLATION

WARNING: The unit must be connected to WC pan with a horizontal outlet spigot conforming to EN33 or EN 37.

The macerator and its connections is integral with the WC pan itself.

The unit should be accessible for possible service.

It is supplied with fixing lugs to prevent it from moving during use.

To optimise the latest technical developments concerning soundproofing incorporated into this unit, it is important to:

- position the WC pan so that it is not in contact with a partition or wall of the room
- place the WC pan on a perfectly level surface to ensure that the resilient mounts are fully efficient
- fix the discharge pipe correctly, with distances of not more than one metre between the fastenings.

7a WC CONNECTION

- First, put some silicon or liquid soap on the WC spigot
- Fit the collar supplied on the bowl outlet
- Pull the flexible sleeve over the pan spigot
- Position the jubilee clip over the edge of the flexible sleeve, and tighten with a screwdriver
- Once the appliance has been positioned, fix it to the floor using the 2 screws supplied.

If using the two floor fixing lugs, secure them to the floor before positioning the unit.

WARNING !!!

There should be no dripping of water from the WC cistern or any other sanitary appliances. If there is, this will cause the unit to activate repeatedly as it pumps the water away.

7b CONNECTION OF EXTRA SANITARY APPLIANCES

See fig. n° **7b1** et fig. n° **7b2** (cf. technical data sheet) for such connections as may be required for sanitary appliances.

7c CONNECTION OF DISCHARGE PIPEWORK

(cf. technical data sheet fig. **7c**).

- Turn the outlet elbow in the desired direction and then use the rubber hose, making sure it is not kinked and to connect it to the unit. If necessary, use the 23/32 fitting supplied.

7d TECHNICAL ADVICE FOR DISCHARGE PIPEWORK

(cf. technical data sheet fig. **7d**).

- Horizontal pipe runs must have a minimum fall of 1:200 (5mm per metre) to the soil stack,
- If a vertical lift is required, it must be made before the horizontal run at the start of the pipe run,
- We would recommend that a drain-off point is installed to allow the discharge pipework to be drained down before any service work,

- If the discharge pipework runs to a level considerably lower than the unit, the resultant syphoning effect can suck out the water seal in the unit. Fitting an air admittance valve (BBA approved) at the high point of the pipe run will overcome this problem,
- The discharge pipework must be connected to the soil stack using an appropriate strap on boss,
- Ensure all external pipework is adequately lagged to avoid the possibility of freezing.

N.B. : Any elbow on the discharge pipe of the unit will create friction loss (roughly 50 cm per elbow to be deducted from the horizontal pumping spec.)

Always use smooth bends (OR 2 X 45 degree bends together) and not 90 degree elbows.

7e CONNECTION TO THE ELECTRICAL SUPPLY



The electrical installation should be carried out by a qualified person, and conform to BS7671 1992 requirements for electrical installation.

The unit requires a 230v/240v single-phase AC50 HZ supply (UK specification) and should be connected to an unswitched fused wiring connector protected by a 5 amp fuse or circuit breaker (30mA).

The wires in the mains lead of the Sanipack® are coloured as follows:

Brown	=	Live
Blue	=	Neutral
Green/Yellow	=	Ear

8 NORME

- This appliance conforms to EN 12050-3. Lifting plant for wastewater containing faecal matter for limited applications and the European directives and standards concerning electrical safety and electromagnetic compatibility.

9 COMMISSIONING THE UNIT

Once electrical and plumbing connections have been made, flush the WC once. The motor should run from 5 to 10 seconds to clear the waste (depending on the height of the pipe run). If it runs for more than 20 seconds, check that the pipework is clear, and that the discharge hose is not kinked. Flush the WC checking that all seals, and connections are watertight. Check both the discharge pipework from the unit and the other sanitary appliances connections.

10 USAGE AND WARNING

WARNING !!!

If away for a long periods (eg holidays) we recommend that you turn off the water supply to the WC served by the unit.

WCs connected to this unit can be used like any normal toilet, and requires minimum maintenance. The unit will operate automatically as soon as the required level of water enters the case.

This is a domestic unit.

For horizontal pipework:

- Minimum fall of 1:200 to the soil stack,
- Avoid any dips in the discharge pipe.

WARNING !!!

Only the disposal of toilet papers, faecal matter, and waste water will be under guarantee. Any damage due to foreign bodies such as cotton, condoms, sanitary towels, wet wipes, food, hair, metal, wood or plastic objects, will not be under guarantee. Solvents, acids and other chemicals can also cause damage to the unit, and will invalidate the guarantee.

11 CARE OF YOUR UNIT

In order to remove scale and clean the macerator and the bowl, use a household descalent.

- Disconnect the macerator power,
- Pour an amount of descalent in the pan
- leave it to stand for 1 or 2 hours,
- Re-connect the macerator power,
- Rinse by operating the flushing system twice.

Carry out the operation once every 3 months on average, but the frequency may need to be changed depending on the hardness of the water.

12 MAINTENANCE



DISCONNECT THE ELECTRICAL POWER SUPPLY, BEFORE ATTEMPTING ANY WORK ON THE UNIT.

No need of any particular maintenance.

This unit is fitted with an active carbon filter, and requires no external venting. This filter has to be changed every year.

13 FAULT FINDING / REMEDIES

For the most part, any inconsistencies in the operation of the unit will be minor and easy rectified. Please refer to the chart below.



IN ALL CASES, YOU MUST DISCONNECT THE MACERATOR FROM THE POWER SUPPLY

If the problem cannot be easily remedied in this way, please call our Service organisation.

ALL WORK INVOLVING DISMANTLING OF THE APPLIANCE MUST BE CARRIED OUT BY AN APPROVED REPAIR AGENT

SYMPTOMS	PROBABLE CAUSES	REMEDIES
<ul style="list-style-type: none">• The unit stops	<ul style="list-style-type: none">• An object is blocking the blades• The unit has been running for too long	<ul style="list-style-type: none">• Ask an approved repair agent to intervene
<ul style="list-style-type: none">• The motor intermittently activates	<ul style="list-style-type: none">• The connected sanitary devices are leaking• The non-return valve is faulty	<ul style="list-style-type: none">• Check the installation upstream• Clean or replace the non-return valve
<ul style="list-style-type: none">• The water in the WC pan goes down very slowly	<ul style="list-style-type: none">• The air dispenser is clogged up	<ul style="list-style-type: none">• Clear the air dispenser
<ul style="list-style-type: none">• The motor operates normally, but continues to run for a long time	<ul style="list-style-type: none">• The length or height of the installation is over the specification, or there are too many bends/elbows• The pump cover plate is occluded	<ul style="list-style-type: none">• Check the installation• Otherwise, ask an approved repair agent to intervene
<ul style="list-style-type: none">• The motor does not activate	<ul style="list-style-type: none">• The electrical power supply is not active• The plug is defective• The motor is defective or the control system	<ul style="list-style-type: none">• Restore the electrical supply,• Repair the plug,• Call a service engineer to check the motor• Otherwise, ask an approved repair agent to intervene
<ul style="list-style-type: none">• The motor emits a rattling or crunching sound, hums, but does not run	<ul style="list-style-type: none">• Foreign object into the box• Problem with the motor or the control system	<ul style="list-style-type: none">• Remove the foreign body (see section 14)• Otherwise, ask an approved repair agent to intervene
<ul style="list-style-type: none">• Cloudy water comes up into the shower basin (units with side inlets)	<ul style="list-style-type: none">• Shower installed too low as compared with the macerator unit• Hinged side inlet discs clogged up	<ul style="list-style-type: none">• Check the installation• Clean the hinged discs (see section 14)• Otherwise, ask an approved repair agent to intervene

14 REMOVAL



DISCONNECT THE ELECTRICAL POWER SUPPLY BEFORE ANY SERVICE

REMOVING THE UNIT FROM THE WC SUITE

- (A) **Disconnect the electrical power supply,**
- (B) Turn off the water feed to the WC cistern. Bail out as much water as possible from the cistern,
- (C) Remove discharge hose from elbow,
- (D) Disconnect any inlet pipes from the unit,
- (E) Unscrew the 2 fastening screws (to the floor) if fitted,
- (F) Remove the flexible connector off the WC pan spigot and slide the flexible connector off the WC spigot and slide the unit out from behind the WC.

HINGED SIDE INLET VALVES CLOGGED

Remove the sleeves and use a screwdriver to free or clean the rubber flaps if necessary.

15 GUARANTEE

2 years guarantee as from its date of purchase subject to correct installation and correct use.

FRANCE

**SOCIETE FRANÇAISE
D'ASSAINISSEMENT**
8, rue d'Aboukir
75002 Paris
Tél. 01 44 82 39 00
Fax 01 44 82 39 01

UNITED KINGDOM

SANIFLO Ltd.,
Howard House, The
Runway
South Ruislip (Middx.,)
HA4 6 SE
Tel. (0208) 842 0033
Fax (0208) 842 1671
Telex: 934 335 G SANFLO

ESPAÑA

GRUPO SFA
C/ Cuzco, 41
08030 Barcelona
Tel. (93) 381 85 97
Fax (93) 462 18 96

www.sfa.biz

DEUTSCHLAND

SFA SANIBROY GmbH
Waldstr. 23 **Geb. B5**
63128 Dietzenbach
Tel. (060 74) 30928-0
Fax (060 74) 30928-90

BENELUX

SFA BENELUX B.V.
Vultaweg 4
6101 XK Echt
Tel. +31 475 487100
Fax +31 475 486515

CANADA

SFA-SANIFLO INC.
1-685 Speedvale
Avenue West
Guelph ON - N1K 1E6
Tel. +1 519 824 1134
Fax +1 519 824 1143

SVERIGE

SANIFLO AB
BOX 86
S-133 22 Saltsjöbaden
Tel. 08-717 5680
Fax 08-717 8686

ITALIA

SFA ITALIA spa
Via del Benessere, 9
27010 Siziano (PV)
Tel. 03 82 61 81
Fax 03 82 61 8200

РОССИЯ

SFA РОССИЯ
101000 Москва
Колпачный пер.
9а, ком. 103
Тел. (095) 921 87 71
факс (095) 921 87 71

IRELAND

SANIRISH Ltd
IDA Industrial Estate
Edenderry
County Offaly
Tel. + 353 46 9733 102
Fax + 353 46 97 33 093

POLSKA

SFA POLAND
ul. Kolejowa 33
05-092 Łomianki/Warszawa
Tel. (+4822) 732 00 32
Fax (+4822) 751 35 16

SERVICE HELPLINES

	TEL	FAX
France	► N°Azur 0 810 05 90 02 <small>1 UT par appel</small>	03 44 94 46 19
United Kingdom	(08457) 650011 <i>(CALL FROM A LANDLINE)</i>	(0208) 8421671
Canada	+1 800 363 5874	+1 519 824 1143
Deutschland	0800 82 27 82 0	(060 74) 30928-90
España	(93) 381 85 97	(93) 462 18 96
Benelux	+31 475 487100	+31 475 486515
Italia	800 636394	+39 0382 618200
Sverige	08-744 15 18	08-717 8686
Россия	(095) 921 87 71	(095) 921 87 71
Ireland	+ 353 46 97 33 102	+ 353 46 97 33 093
Polska	(+4822) 732 00 33	(+4822) 751 35 16

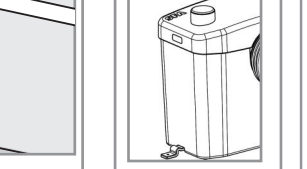
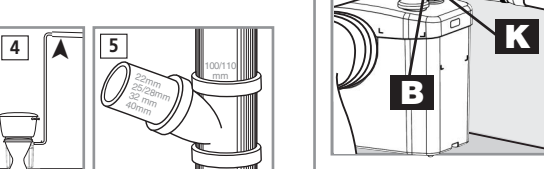
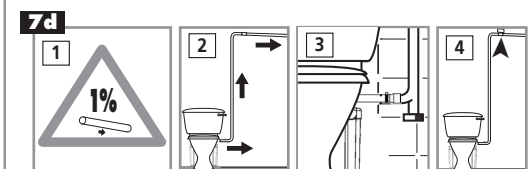
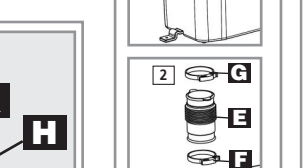
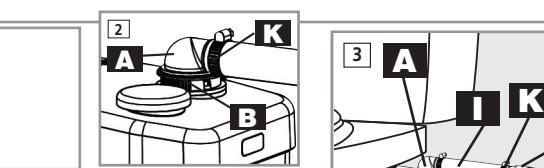
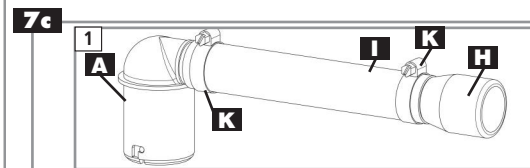
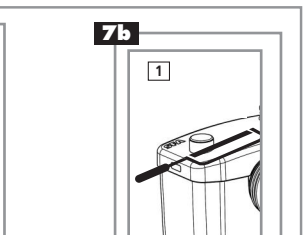
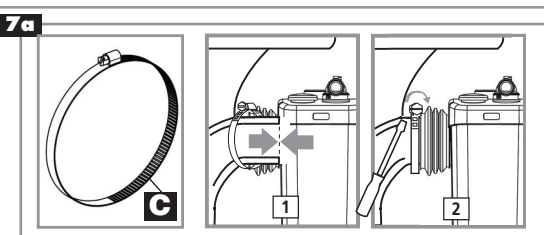
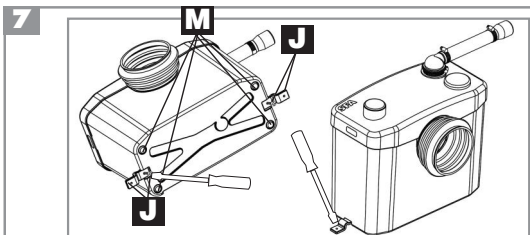
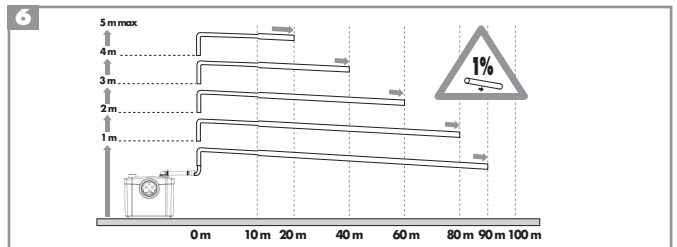
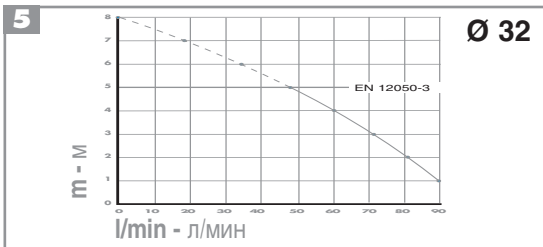
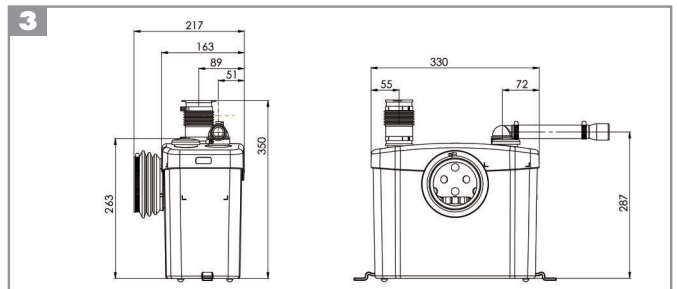
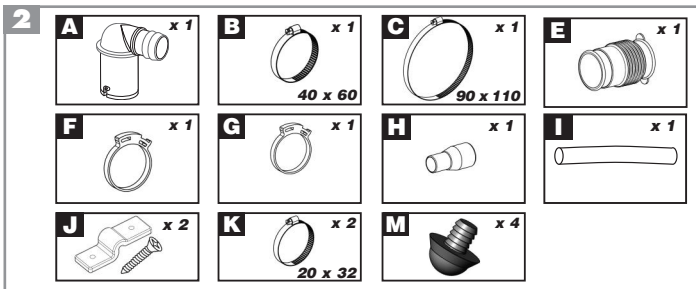
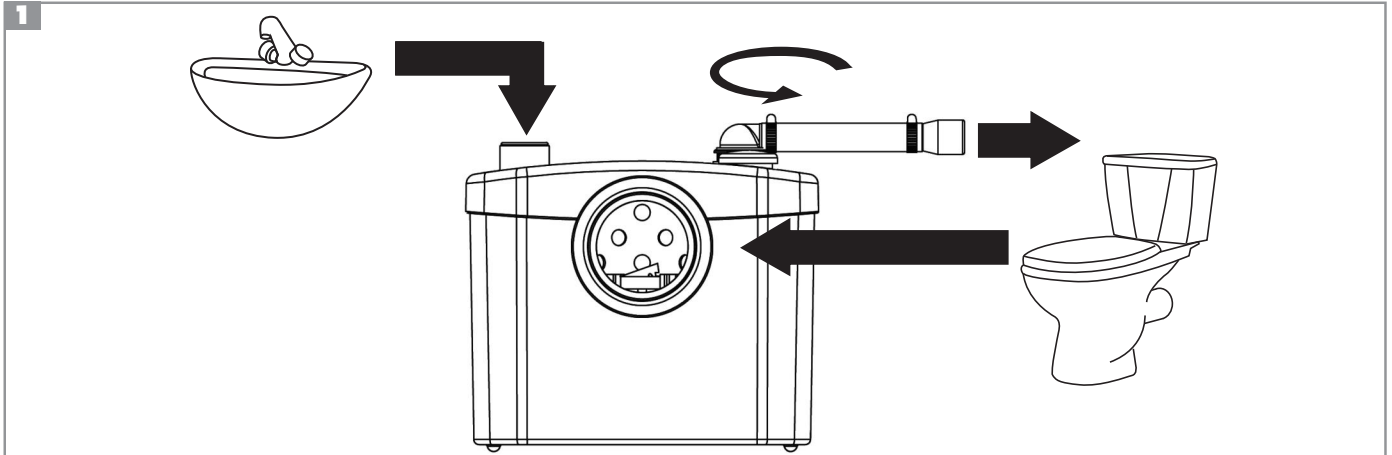

7 SUITE

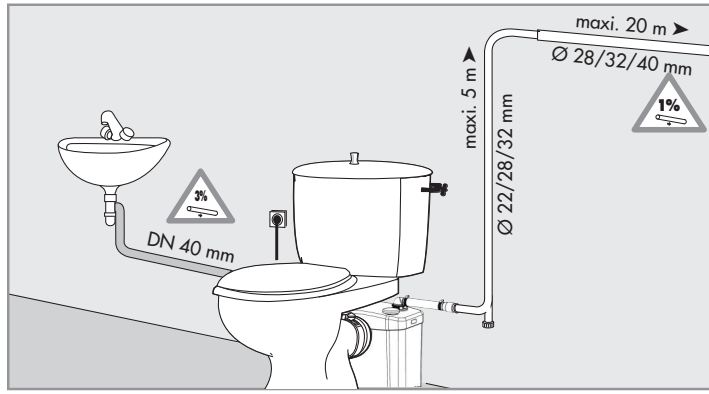

8

SANITOP®
 Société Française d'Assainissement
EN 12050-3

LA01-X10
 220-240 V - 50 Hz - 550 W - IP44 - 2,9 A
 - 5,4 KG

